

**Features**

- Built-in 100v/70v transformer
- Waterproof projector type loudspeaker
- Supreme longer distance dispersion horn speaker
- IP65 waterproof level
- Power taps 15w-30w @100V
- ABS enclosure and metal bracket

**Description**

The T-720A is a waterproof horn speaker built-in 70v/100v transformer. The 70v/100v transformer technique reduces line losses on longer distance and allows easy parallel connection of multiple loudspeakers.

The built-in horn speaker driver is designed of wide frequency response 300-13kHz, the multiple power taps 15W & 30W are helpful for different applications varies from room size and ambient noise surroundings.

The ABS enclosure and metal bracket are of white color. Easy and secure wall mount installation through the supplied mounting bracket.

It is ideal choice for industrial and commercial applications in the outdoor area of parking, park, garden, corridor and playground where paging is needed.



**Specification**

Model	T-720A
Power Taps @100V	15W, 30W
Power Taps @70V	7.5W, 15W
Impedance	Black: Com Green: 670Ω White: 330Ω
SPL(1W/1M)	103dB±3dB
Max. SPL (Rated W/1M)	117dB
Frequency Response (-10dB)	300-13KHz
Finish	Baffle: ABS, White
IP Rate	IP66
Dimensions	282 x 210 x 290mm
Weight	2.1Kg
Mounting	With mounting bracket fixed by screw

**Appearance:**

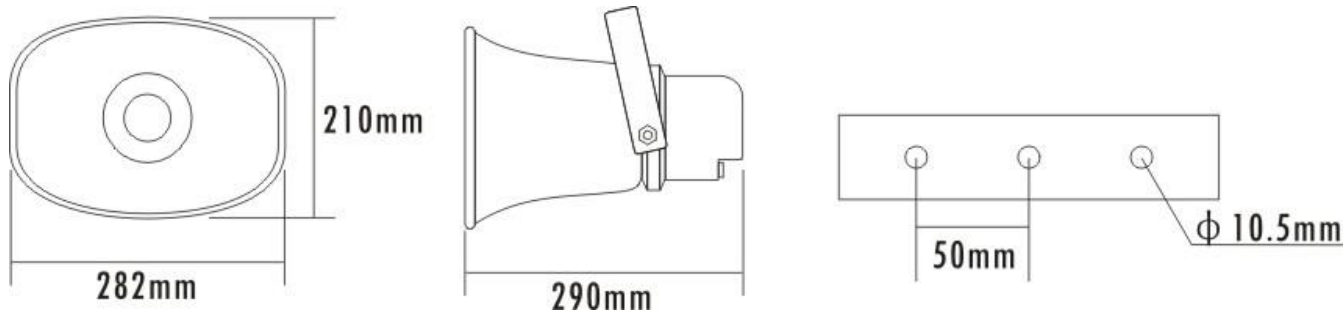

**Direction Diagram:**

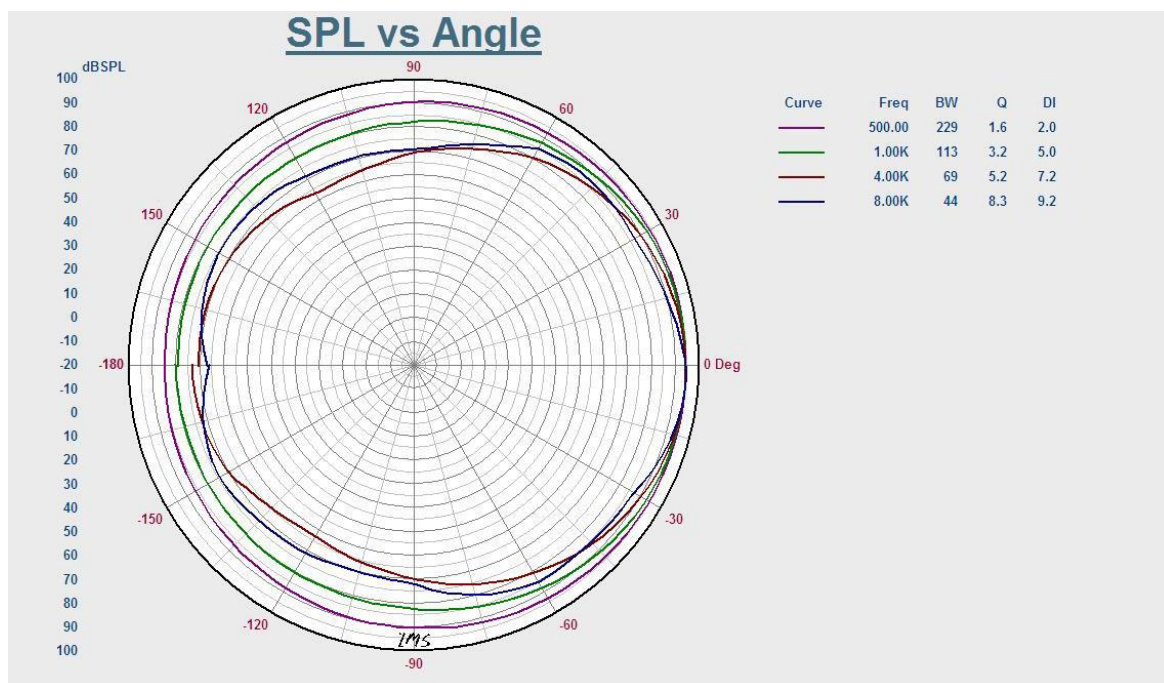

**Frequency Response:**

